



Model E Alarm Check Valve

Instructions for Installation, Operation, Care and Maintenance

**4"(100 mm), 6"(150 mm),
8"(200 mm) Sizes
With Model E3 Trim**

Listed by Underwriters Laboratories, Inc. Approved by 'FM Approvals', and other fire insurance and governmental agencies in the United States and foreign countries.

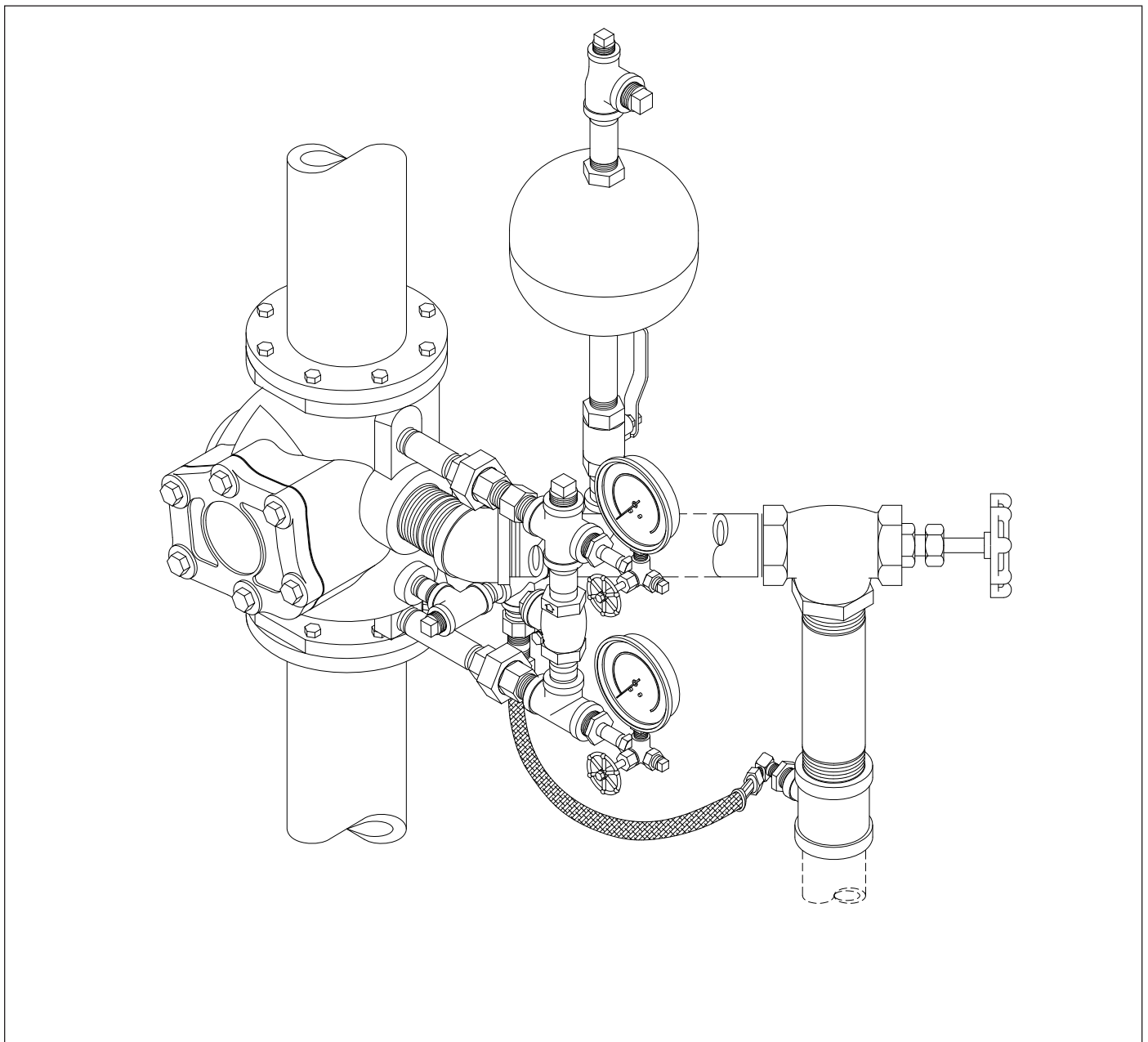

General

Reliable Model E Alarm Check Valves are installed in either the vertical or horizontal position in the main supply to the wet pipe system. Variable pressure water supply requires the use of either of two Model E-3 variable pressure trim sets and a Reliable Model E-1 Retard Chamber. Constant pressure water supply requires the use of a Model E-3 constant pressure trim set only. Model E Alarm Valves are shipped with the designated Model E-3 trim set, i.e., variable/open drain, variable/closed drain or constant pressure.

Valve Description

1. Rated working pressure 175 psi (12,1 bar).
2. Factory hydrostatic test pressure 350 psi (24, 2 bar).
3. End and trim connections—Three valve connection styles are available.
 - a. US Standard Flanged Inlet and Outlet
 - Flanges mate with ANSI B 16.1 (125 lb.) Flange

U.S. Flange Dimensions in Inches (mm)					
Valve Size	Bolt Circle Dia.	Bolt Hole Dia.	Flange Outside Dia.	Flange Thickness	No. Bolts
4" (100)	7½	¾	9 ¹⁵ / ₁₆	¹⁵ / ₁₆	8
6" (150)	9½	7/8	11	1	8
8" (200)	11¾	7/8	13½	1½	8

- Threaded openings per ANSI B 2.1
 - Reliable's standard trim sets are compatible with 4" (100mm), 6" (150mm) & 8" (200mm) US Flanged Valves.
 - Color — Black
- b. US Standard Flanged Inlet and Grooved Outlet (Fig. 1):

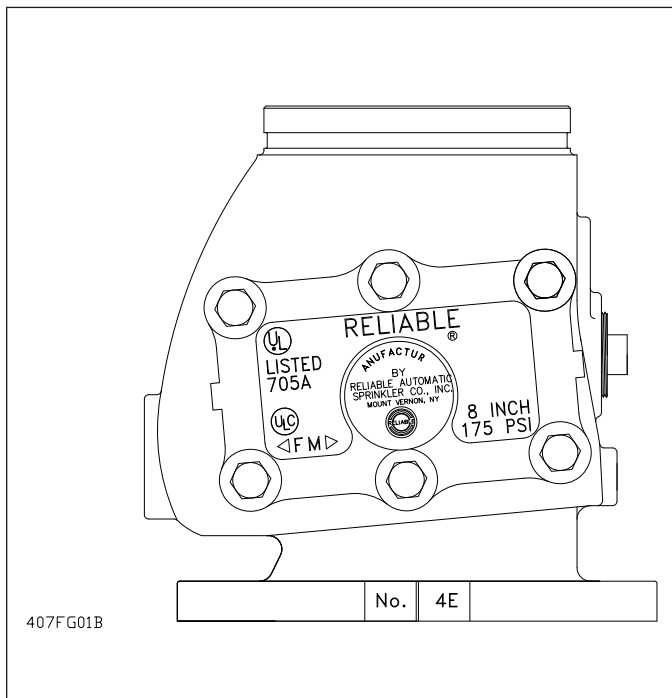

Fig. 1

- Inlet flange mates with ANSI B 16.1 (125 lb.) Flange.
- Outlet groove dimensions per ANSI/AWWA C606.

U.S. Groove Dimensions in Inches (mm)				
Valve Size	Outlet Dia.	Groove Dia.	Groove Width	Outlet Face to Groove
4" (100)	4.500 (114)	4.334 (110)	3/8 (9.5)	5/8 (16)
6" (150)	6.625 (168)	6.455 (164)	3/8 (9.5)	5/8 (16)
8" (200)	8.625 (219)	8.441 (214)	7/16 (11.11)	3/4 (19)

- c. Metric flanged inlet and outlet
 - 100 and 150mm valve plain face flanges mate with DIN 2501, NF-E-29-282, ISO 2084 NP10 and NP16 and BS4504 NP10 and NP16.
 - 200 mm valve raised face flanges mate with DIN 2501, ISO 2084NP16 and BS4504 NP16.

Metric Flange Dimensions in Millimeters							
Valve Size	Bolt Circle Dia.	Bolt Hole Dia.	Raised Face		Flange Outside Dia.	Flange Thickness	No. Bolts
			Dia.	Ht.			
100 mm	180	18.3	—	—	229	23.8	8
150 mm	241	22.2	—	—	279	25.4	8
200 mm	295	22.2	268	3	343	28.6	12

- Threaded openings per ISO 7/1-R.
 - Reliable's standard trim sets may be used with metric valves providing trim is assembled carefully and extra thread sealant is applied to connections between valves and trim.
 - Color — Red
4. Face to Face Dimension
 - For the 4" (100 mm) valve — 11¾" (299 mm)
 - For the 6" (150 mm) valve — 13½" (343 mm)
 - For the 8" (200 mm) valve — 14½" (368 mm)
 5. Shipping Weight:

	Flanged Inlet and Outlet	Flanged Inlet and Grooved Outlet
4" (100 mm)	80 lb. (36.3 kg)	70 lb. (31.8 kg)
6" (150 mm)	116 lb. (52.6 kg)	102 lb. (46.3 kg)
8" (200 mm)	155 lb. (70.3 kg)	143 lb. (64.9 kg)
 6. Friction Loss — expressed in Equivalent Length of Pipe, Based on Hazen & Williams formula with C=120.

	Equiv. Length
For the 4" (100 mm) valve	17' (5.18 m)
For the 6" (150 mm) valve	27' (8.23 m)
For the 8" (200 mm) valve	29' (8.84 m)

Trim Description

The E3 trim sets for the Reliable Model E Alarm Valve (Fig. 2) are arranged for rapid, easy and compact attachment, and serves as connection points to Reliable Alarm and other devices. The trim also serves as means for testing the operation of the alarm devices without causing the system to operate. Three basic Model E-3 trim sets are available for use with the Model E Alarm Valve:

- **Constant Pressure Closed Drain—**

Retard chamber is not required.

This trim set is used where water supply pressure does not vary. An automatic draining is provided to drain the mechanical sprinkler alarm line. This drain connection should be piped separately from the 2" (50mm) main drain.

- **Variable Pressure with Closed Retard Chamber Drain —**

Model E1 Retard chamber is required. This trim set is used where water supply pressures vary. The retard chamber and the mechanical sprinkler alarm line are drained through a closed connection to the 2" (50mm) drain line. Only one drain connection is required.

Each Model E-3 basic trim set permits either horizontal or vertical installation.

- **Variable Pressure with Open Retard Chamber Drain**

Model E1 Retard chamber is required.

Optional Drain Line Kit required (Figs. 2, 3 & 5). This trim set is used where water supply pressures vary. An open drip cup is provided to drain the retard chamber and the mechanical sprinkler alarm line. This drain connection should be piped separately from the 2" main drain.

Note: Connection to drain (by customer) must allow safe discharge of water from main drain at full system pressure, and also allow gravity draining of the alarm line trim. Care shall be taken to prevent back pressurization of system main drain.

Alarm valves are listed and approved by Underwriters Laboratories, Inc. and Factory Mutual Corp. only when used with the valve manufacturer's trim sets.

Trim kits are available, galvanized and in three trim styles:

- Individual Part Trim
- Pre-Assembled Trim
- Factory Trimmed Valve

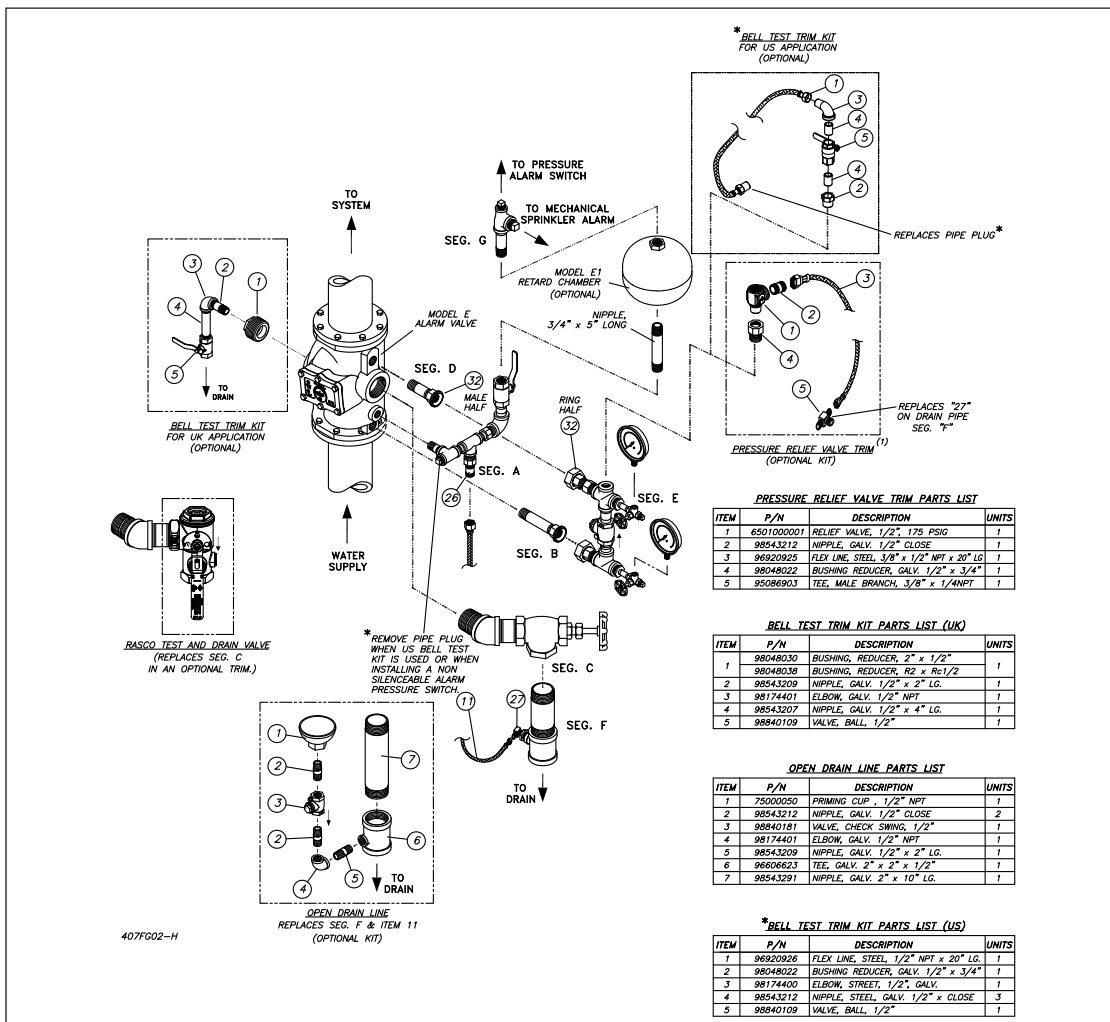

Fig. 2—Model E 8" Flanged Inlet and Outlet Alarm Valve Variable Pressure Open Drain Trim

Pressure Relief Trim Kits

All wet pipe systems being installed in accordance with the 2010 edition (or newer) of NFPA 13 are required to have a pressure relief valve. For convenience, an optional pressure relief valve kit (illustrated in Fig. 2) is available.

Assembly of Model E3 Trim

• Variable Pressure Vertical Installation (Fig. 2)

The following description is the recommended sequence for installing the trim as illustrated in this bulletin.

1. After the alarm check valve has been installed in the riser, attach Segment "A" in the orientation shown and in a leak tight condition.
2. Insert Segment "B" leak tight. **Note:** Segment "B" is the larger of the two union connections.
3. Install Segment "C" leak tight and orientate as shown by wrenching on the 45 degree elbow.

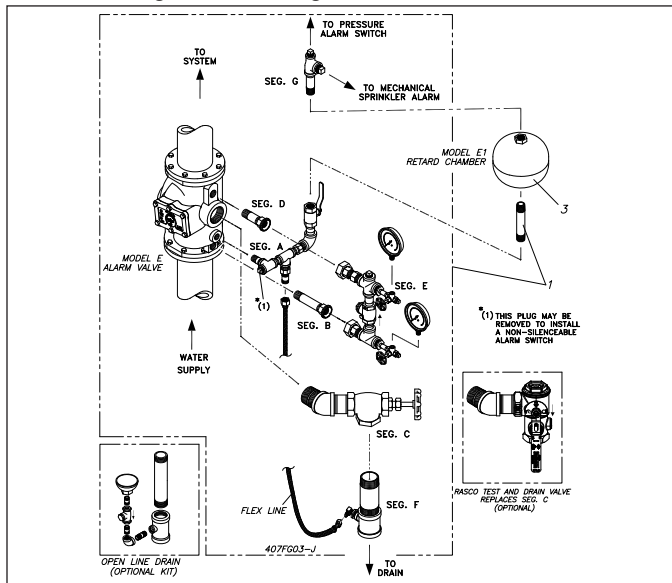

Fig. 3 Variable Pressure Vertical Installation

4. Install Segment "D" leak tight.
5. Attach Segment "E" at the unions. Verify that the arrow on the check valve is pointing to system.
6. Install the gauges.
7. Install Segment "F" leak tight by wrenching on the 2" (50mm) tee. Orientate the tube fitting towards the back of the alarm valve. Connect Item 26 (alarm line drain port) to Item 27 in the drain line using the flex tubing provided (Item 11). Note: the tubing should be free of kinks. Note: An open line drain kit segment is optional, to be purchased separately, as a replacement to seg. F (Fig. 3) & Seg. H (Fig. 5).
8. Install 3/4" x 5" (20mm x 127mm) long galvanized nipple, Model E1 Retard Chamber and Segment "G" in the orientation shown and in a leak tight condition.
9. Connect appropriate water flow alarm devices.

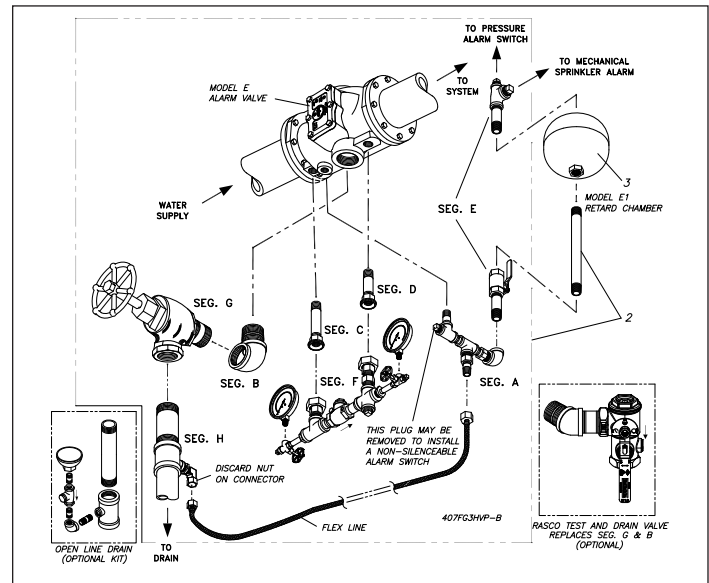

Fig. 5 Variable Pressure Horizontal Installation

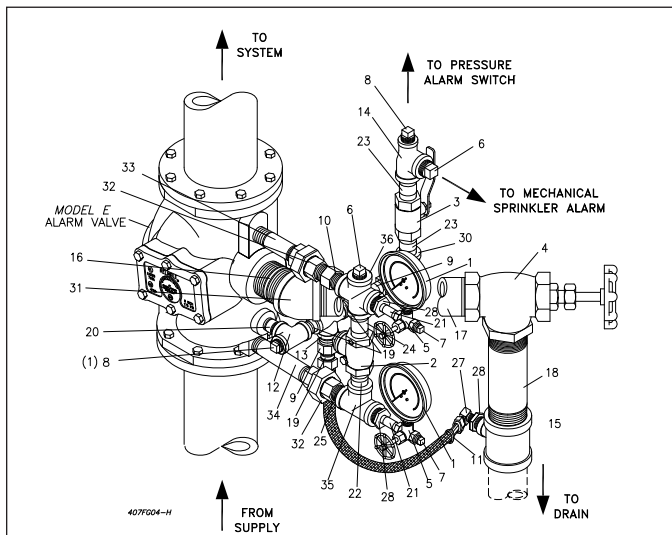

Fig. 4 Constant Pressure Vertical Installation

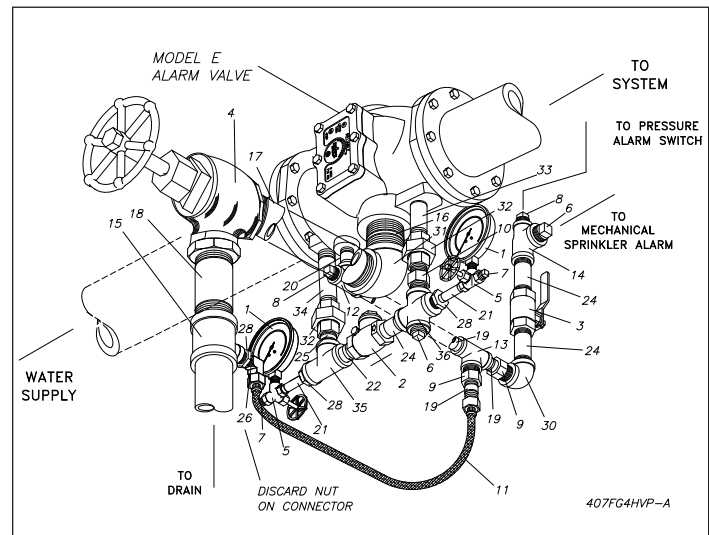

Fig. 6 Constant Pressure Horizontal Installation

Variable Pressure (Figs. 3 & 5)

Item No.	Part No.		Description	Remarks	No. Req'd
1	6502141415	Vertical	Trim, Model E3 Closed Drain, Seg., 4" & 6"		1
	6502141414	Vertical, Optional	Trim, Model E3 Closed Drain, Seg., 4" & 6"		1
	6502141436	Vertical	Trim, Model E3 Closed Drain, Seg., 8"		1
	6502141432	Vertical, Optional	Trim, Model E3 Closed Drain, Seg., 8"		1
2	6502141418	Horizontal	Trim, Model E3 Closed Drain, Seg., 4" & 6"		1
	6502141413	Horizontal, Optional	Trim, Model E3 Closed Drain, Seg., 4" & 6"		1
	6502141438	Horizontal	Trim, Model E3 Closed Drain, Seg., 8"		1
	6502141434	Horizontal, Optional	Trim, Model E3 Closed Drain, Seg., 8"		1
3	6303000522		Retard Chamber		1

Constant Pressure (Figs. 4 & 6)

Item No.	Part No.		Description	Remarks	No. Req'd
	6502141415	Vertical	Trim, Model E3 Closed Drain, Seg., 4" & 6"		1
	6502141414	Vertical, Optional	Trim, Model E3 Closed Drain, Seg., 4" & 6"		1
	650214118	Horizontal	Trim, Model E3 Closed Drain, Seg., 4" & 6"		1
	6502141413	Horizontal, Optional	Trim, Model E3 Closed Drain, Seg., 4" & 6"		1
	6502141436	Vertical	Trim, Model E3 Closed Drain, Seg., 8"		1
	6502141432	Vertical, Optional	Trim, Model E3 Closed Drain, Seg., 8"		1
	6502141438	Horizontal	Trim, Model E3 Closed Drain, Seg., 8"		1
	6502141434	Horizontal, Optional	Trim, Model E3 Closed Drain, Seg., 8"		1
	6502141414		Trim, Model E3 Closed Drain, Seg., 4" & 6"	Items 1 - 36	
1*	98248001		Gauge, Water Pressure (0 - 300 psi)		2
2	98840180		Valve, Hor. Check, 3/4"		1
3	98840108		Ball Valve, 3/4"		1
4	98840131		Valve, Reliable TD test & drain, Optional		1
	98840100		Valve, Angle, 2"		1
5	98840160		Valve, Gauge, 3-Way, 1/4"		2
6	98614401		Plug, 3/4"		2
7	98614403		Plug, 1/4"		2
8	98604406		Plug, 1/2"		2
9	98580002		Orifice, Drain, 3/16" Orif., 3/4" NPT x 1/2" NPT		2
10	98580006		Orifice, Retard, 3/8" Orif., 3/4" NPT		1
	98580007		Orifice, Retard, 7/16" Orif., 3/4" NPT		1
11	96909925	Vertical	Flex Line, Steel Braided 3/8" OD (1/4" NPT) x 1/2" FIP	9" Long	1
	96920925	Horizontal	Flex Line, Steel Braided 3/8" OD (1/4" NPT) x 1/2" FIP	20" Long	1
12	98761651		Tee, 1/2"		1
13	96606603		Tee, 1/2" x 1/2" x 3/4"		1
14	96606610		Tee, 3/4" x 1/2" x 3/4"		1
15	96606623		Tee, 2" x 2" x 1/2"		1
16	98543238		Nipple, 2" x Close		1
	98543401		Nipple, R2 / 2" NPT Close (Optional)		
17	98543208		Nipple, 2" x 3" LG.		1
18	98543273		Nipple, 2" x 5 1/2" LG.		1
19	98543212		Nipple, 1/2" x Close		2
20	98543209		Nipple, 1/2" x 2" LG.		1
21	98543226		Nipple, 1/4" x 1 1/2" LG.		2
22	98543215		Nipple, 3/4" x 1 1/2" LG.		1
23	98543233		Nipple, 3/4" x 2 1/2" LG.		1
24	98543231		Nipple, 3/4" x 3" LG.		2
25	98543215		Nipple, 3/4" x Close		1
26	92056702		Connector, Male, 3/8" Tubing x 1/4" NPT		1
27	92056703		Elbow, Male, 3/8" Tubing x 1/4" NPT	See Fig. 2	1
	6502141420		Open Drain Optional / Kit	See Fig. 2	1
28	98048025		Reducer Bushing, 3/4" x 1/4"		2
29	98174401		Elbow, 1/2"		1
30	98174402		Elbow, 3/4"		1
31	98174411		Elbow, 2", 45°		1
32	98815202		Union, 3/4"		2
33	98543282		Nipple 3/4" x 4" LG.		1
34	98543242		Nipple 3/4" x 5" LG.		1
35	96606601		Tee 3/4"		1
36	98750005		Cross 3/4"		1

* Optional 0 - 600 psi Gauges Specify P/N 98248005

- **Constant Pressure Vertical Installation (Figs. 2, 3 & 7)**

The Trim for this installation follow the same sequence given in Steps 1 through 9 above. The only exception is step 8 where Segment "G" is installed directly into the 3/4" (20mm) shut-off valve in Segment "A".

Note: In all cases, carefully install the check valve in the position shown with the flow arrow pointing in the direction shown.

- **Horizontal Installation (Figs. 5, 6 & 8)**

Follow a sequence similar to that given above for vertical installation, and refer to Figs. 5 & 6 for illustration.

- **Variable Pressure Equipment**

The normal position of the alarm valve parts is shown in Fig. 9. Flow of water in the system piping resulting from the discharge through one or more fused automatic sprinklers causes the Clapper (4) to rise off the Grooved Seat (3) and permits water from the supply piping to enter the system.

The movement of Clapper (4) on Hinge Pin (8) uncovers the groove in Seat (3) and allows water to flow through the groove into the Alarm Line Outlet and to the Alarm Line, Fig 5.

Continual flow of water fills the retard chamber and flows to mechanical and/or electric alarms. (For details on mechanical and electric alarms, refer to their individual instruction sheets.) A small amount of water will simultaneously flow into the drain line.

When the water ceases to flow through the Alarm Valve, the Clapper (4) returns to its seat thus stopping the flow of water to the retard chamber. Drain Orifices (Item 9, Fig. 4 & 6) allow the retard chamber and alarm line to empty through the drain line (Item 11, Fig. 4 & 6).

Virtually all sprinkler system piping contains confined air. If a water hammer or pressure surge occurs in the supply line, the increased pressure will compress the confined air and cause the alarm valve clapper to lift intermittently which may result in false alarms.

The Model E Alarm Valve with E3 Trim minimizes false alarms under these conditions by two features:

1. The Bypass Line, Fig. 7, with Check Valve (B) allows surges to pass from the supply to the system side of the alarm valve clapper without lifting the clapper off its seat. Repeated surges build up an effective excess pressure in the system which steadies the clapper and prevents false alarms. Should a heavy surge force the clapper off its seat and allow water to flow into the alarm line, the Model E1 Retard Chamber comes into action.

2. The retard chamber and the restriction and drain orifices allow intermittent flows to be drained before they can fill the chamber and pass on to operate the electric and mechanical alarms.

Constant Pressure Equipment

The operation of this equipment is the same as described for the variable pressure equipment, except that due to the water supply pressure being constant, the retard chamber is not required. The water, on passing through the groove in the seat of the alarm valve, flows directly to operate the electric and mechanical alarms.

Tests (see Figs. 7 & 8)

To test the readiness of the entire wet pipe system, open the inspectors test connection which should cause the mechanical and the electric alarms to sound. This test connection is usually located on the end or top line of the system and its opening is the equivalent to the fusing of one automatic sprinkler.

To test the operation of the alarm equipment only, open Valve (A), until alarm sounds. For the optional TestANDrain® installation kit open the valve to the "Test" position. Testing this way has the added benefit of exercising the clapper assembly. Should the mechanical sprinkler alarm (water motor) not operate, most likely the strainer is clogged. Remove the strainer cap and filter to clean. Be sure to replace the cleaned filter and tighten cap securely. Refer to Bulletin 613 for cleaning information.

To test supply piping for unobstructed flow, close Valve (C), and open Valve (A) to the drain position. When test is completed, close Drain Valve (A) securely and open Valve (C) which must be monitored with a suitable supervising device.

For FM insured applications the placement of a TestANDrain® valve (E3 Trim Option) in the 2" (50mm) drain line does not replace the need for an inspector's test connection at the outer reaches of the sprinkler system. The drain valve shall not be used in lieu of the inspector's test connection for the testing of the entire wet piping system. The drain valve shall only be used to exercise the clapper and test valve associated alarm devices. For all other applications please refer to NFPA 13 or to the authority having local jurisdiction.

Maintenance

Reliable alarm valves and associated equipment shall periodically be given a thorough inspection and test. NFPA 25 provides minimum inspection, testing and maintenance requirements. Alarm valves shall be tested, operated, cleaned, inspected and parts replaced, as required, at least annually.

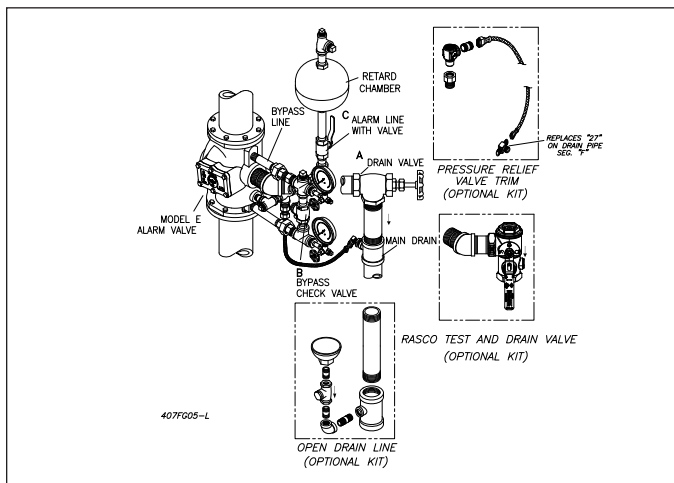

Fig. 7 - E3 Vertical Trim

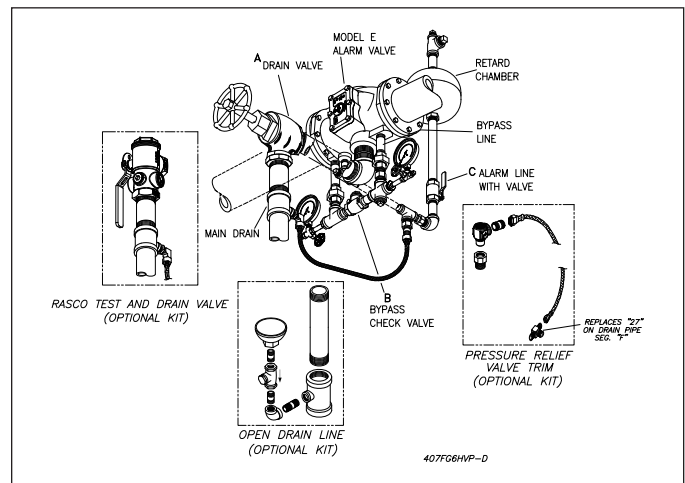

Fig. 8 - E3 Horizontal Trim

Usually, any trouble will be shown by one or more of the following symptoms:

A. Mechanical Sprinkler Alarm (Water Motor) Not Operating.

See **Tests** for corrective measures.

B. Steady Water Flow Into Drain Line

Steps in the following sequence should be taken to correct steady water flow into the drain line:

1. Open Valve (A), Fig. 7, to drain which should flush any loose matter off alarm valve seat. Close valve and observe if water flow ceases.
2. Close main control valve to determine if water flow is coming from above or below alarm valve clapper.

Note: Supply pressure gauge should read '0' psi when main control valve is closed tight and water pressure between this valve and the alarm valve is relieved. If necessary, pressure can be relieved through the lower gauge valve when the 1/4" NPT plug is removed.

- a. If water flow is coming from below clapper, water will stop running to drain line.
- b. If water flow is coming from above clapper, water will continue to run to drain line.

Note: To minimize downtime, the following parts should be on hand before the valve is disassembled:

- 1) Seat installation Wrench:
4" – Part No. 6881240000
6" – Part No. 6881260000
 - 2) Clapper Rubber Facing and Clamping Ring Assembly: Item 5, Figure 9.
 - 3) Seat "O"-Rings: Items 9 and 10, Figure 9.
- c. In either case (a or b), drain system by opening Valve (A), Figs. 7 & 8 to drain. Remove Cover (2), Fig. 9, Shaft Pipe Plug (14), Hinge Pin (8) and Clapper Assembly (4).

Note: Hold down Spring (13) when removing Hinge Pin (8).

- d. Carefully inspect for the following:
 - 1) Damage to clapper rubber facing – Inspect surface for imbedded foreign matter. Replace facing if found damaged (be certain that clapper and clapper clamping ring surfaces are thoroughly cleaned before assembling with new facing.)
 - 2) Damage to seat surface – Clean seat thoroughly. Inspect for any nicks in seat or stones or other foreign matter lodged in seat groove. If seat or other parts of valve are found to be severely damaged, an authorized Reliable distributor should be contacted.
- e. To replace seat "O"-Rings:
 - 1) Using the seat wrench, unscrew the seat. Use care to avoid damage to the seat surface.
 - 2) Remove "O"-Rings, Items 9 and 10, Fig. 9. Thoroughly clean "O"-Ring grooves and sealing surfaces. Inspect for damage or foreign material.
 - 3) Apply a light coat of lubricant to new "O"-Rings and install in the proper grooves. Use care to avoid stretching, twisting or other damage to "O"-Rings.
 - 4) After checking that "O"-Rings are correctly installed, carefully reinstall seat and tighten securely with the seat wrench.

f. To reassemble alarm valve:

- 1) Replace clapper assembly (Fig. 6) on seat alarm valve – insert Hinge Pin (8) in valve and pass it through one bearing of Clapper (4) – Press and hold Spring (13) securely in position between clapper alarm bearings and push clapper alarm shaft through spring coils and bushings to far side of valve – Replace Shaft Pipe Plug (14).
- 2) Lift toe of clapper – check for freedom of rotation and proper seating.
- 3) Replace Cover (2) being sure Cover Gasket (11) is in position and bolts and nuts are securely tightened.
- 4) Close Drain Valve (A), Fig. 7. Slowly open main control valve. Be sure Valve (C) and the main control valve are properly supervised in the OPEN position.

C. False Alarms

False alarms are generally caused by pressure surges in the water supply and can occur if the system loses its effective excess pressure (see "Operation"). Similar readings on the system and supply pressure gauges are a visual indication that the excess pressure condition has been lost. One or more of the following will contribute to this loss of pressure – Leaking system drain valves, leaking at the Alarm Valve Seat (3), Fig. 6, leaking between the Clapper (4) and the Facing (5), or leaking at the Bypass Check Valve (B), Fig. 7.

Corrective Steps:

1. Check system drain valves for tightness.
2. In order to find and correct a leak at the alarm valve seat, proceed as outlined in B.1. through 2.
3. To correct a leak between the clapper and the clapper facing, proceed as outlined in B.2.c. and B.2.d.1.
4. In order to find and correct a leak through the bypass check valve, proceed as follows:
 - a. Close the main control valve and relieve pressure between main control valve and clapper of the alarm valve through the 1/4" NPT lower gauge valve. Close this valve before removing the 1/4" NPT plug, and open after the plug is removed to relieve pressure. If water continues to flow from this valve, the bypass Check Valve (B) should be cleaned, repaired or replaced.
 - b. Bypass Check Valve (B) is leaking, repair after opening Valve (A) to drain and draining the system completely.
 - c. Following all repairs, close Valves (A) and then slowly open the main control valve, and supervise it appropriately.
5. If the retard and mechanical sprinkler alarm line does not drain completely, false alarms may result. In this case, check both drain orifices (Item 9, Fig. 4 & 6) to ensure they are not plugged.

D. Intermittent Alarms

Intermittent alarms are the result of excessive confined air trapped in the sprinkler system piping. To correct this problem, fill the system slowly while venting air at all system openings. When the system is fully pressurized, vent air at all system high points including sprinkler connections if necessary. Contact the installing contractor or Reliable if any difficulties are experienced. Should replacement parts be needed, use only genuine Reliable made parts. When ordering, specify part number, name, size, model and serial number of the unit.

Model E3 Vertical & Horizontal Trim Illustrations
Installation Measurement in Inches (mm)

Valve	A	B	C	D	E	F	G	H	I	J	K	L	M
4 (100)	7 (178)	10½ (267)	16½ (419)	6 (152)	16¾ (426)	15 (381)	3½ (89)	5¾ (146)	12 (305)	4½ (114)	6½ (165)	10 (254)	8¼ (210)
6 (150) (165)	7 (194)	11½ (292)	17½ (445)	7 (178)	15¼ (387)	16½ (419)	4¼ (108)	7 (178)	12 (305)	4½ (114)	6½ (165)	10 (254)	6¾ (172)
8 (200)	7 (194)	11½ (292)	17½ (445)	7 (178)	15¼ (387)	16½ (419)	4¼ (108)	7 (178)	12 (305)	4½ (114)	6½ (165)	10 (254)	6¾ (172)

Installation must be made with 300 psi (20,7 bar) minimum rated couplings, such as the Star Fittings Model C-2 LW. To mate with ANSI Class 250 or Class 300 Flanges, use listed grooved flanged adapters having appropriate pressure rating.

Vertical Variable Trim - Top View

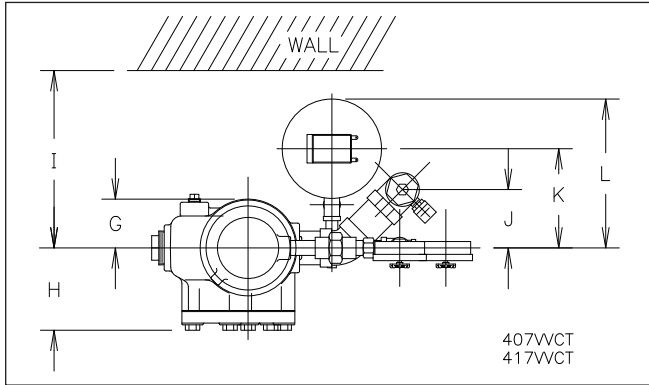

Horizontal Variable Trim - Top View

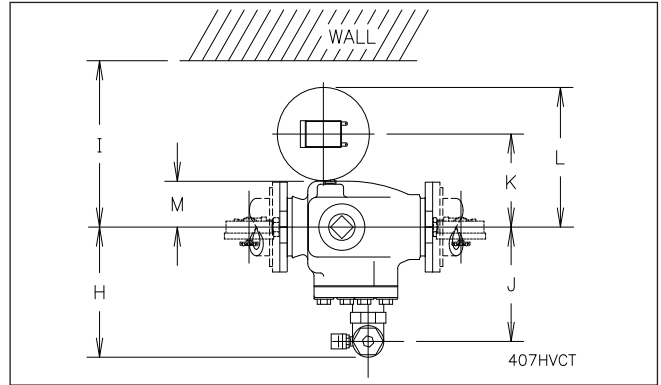

Vertical Variable Trim - Front Elevation

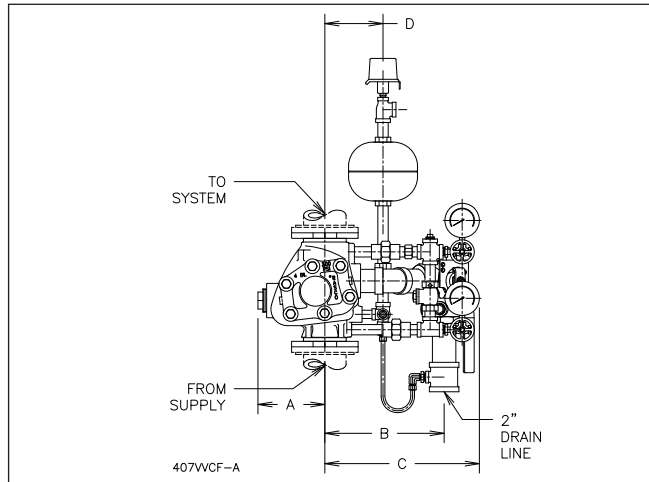

Horizontal Variable Trim - Front Elevation

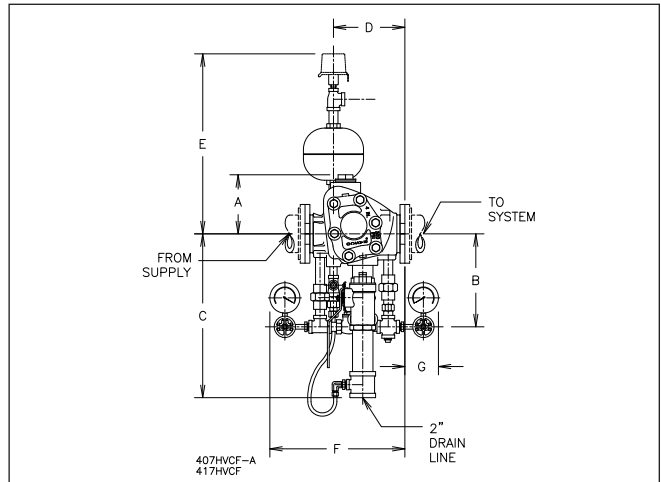

Vertical Constant Trim - Front Elevation

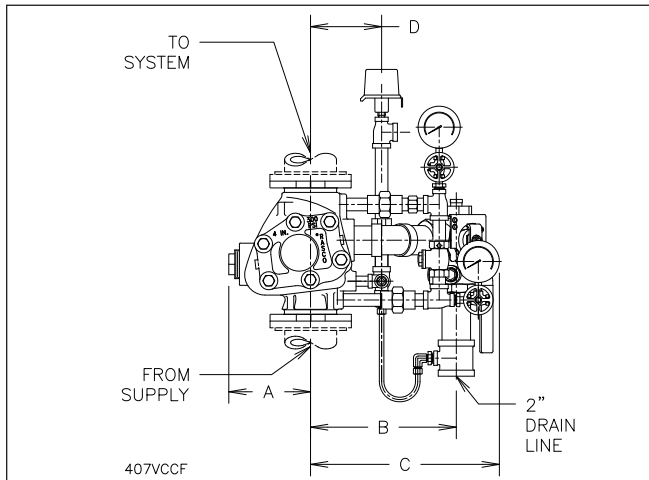

Horizontal Constant Trim - Front Elevation

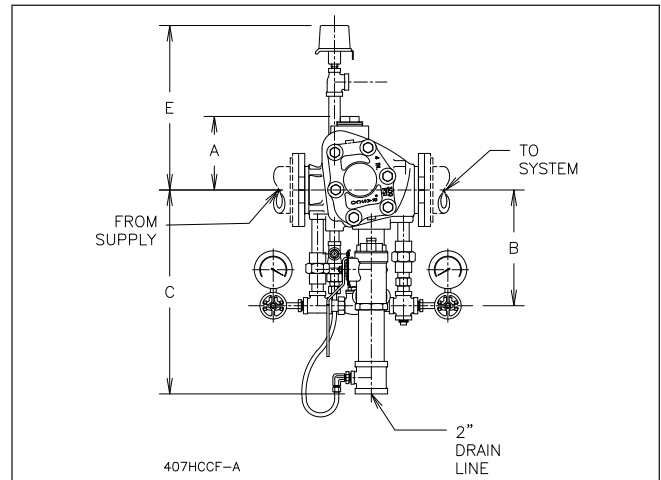

Model E Alarm Valve Parts

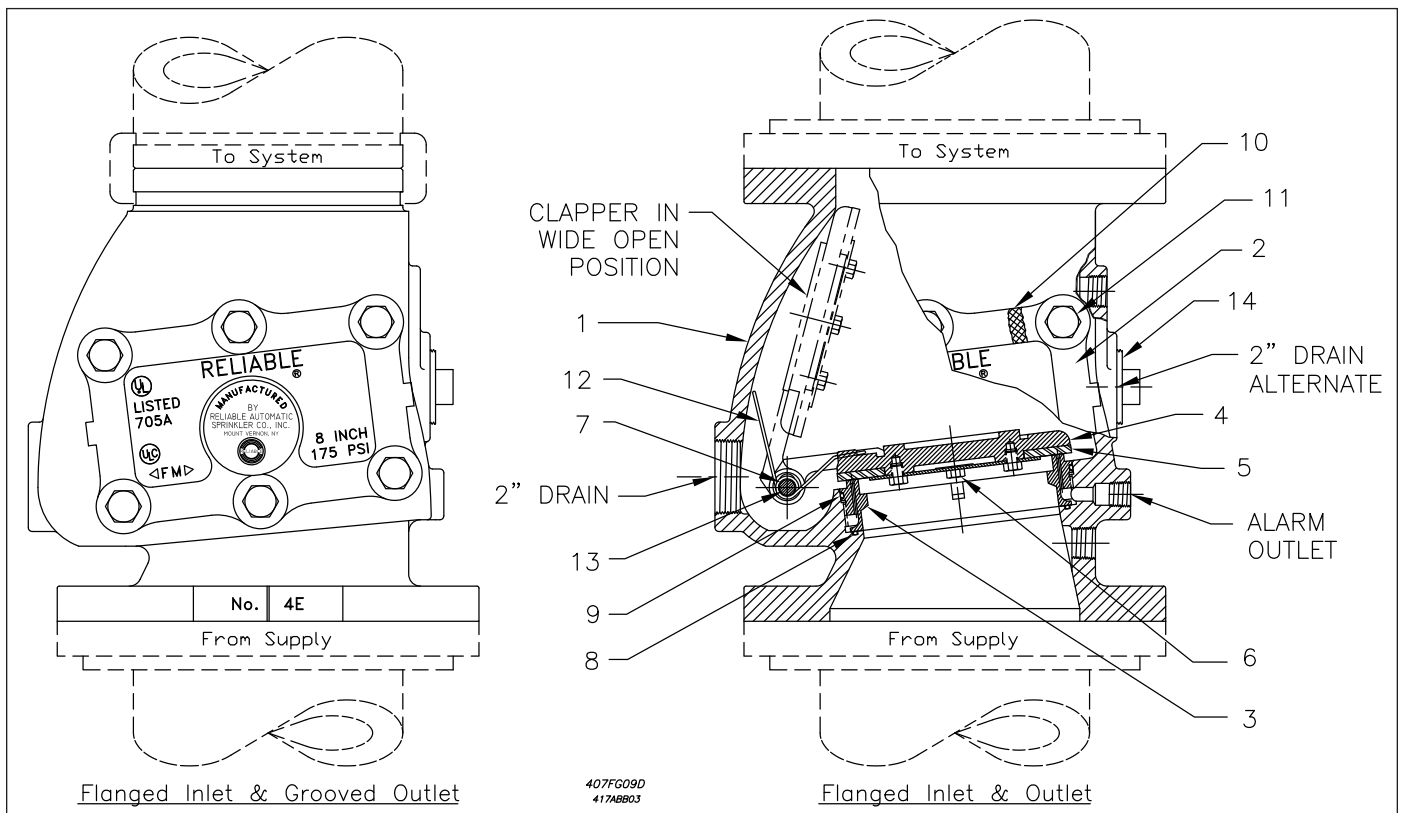

Fig. 9

Parts List for Alarm Valves and Retard Chamber

Item No.	Part Name	Part Number			Material
		4"	6"	8"	
1	Body	--	--	--	Gray Cast Iron Class 30
	Flanged U.S. Standard	91006125	91006127	91006129	--
	Flanged & Grooved U.S. Std.	91006154	91006156	91006158	--
	Metric Flanged	91006130 (100mm)	91006131 (150 mm)	91006132 (200mm)	--
2	Cover	92116124	92116126	92116128	Gray Cast Iron Class 30
3	Seat	96016124	96016126	96016128	Bronze UNS C 83600
4	Clapper & Bushing Assembly	71020424	71020626	71020828	Gray Cast Iron, Brass, EPDM, Stainless Steel
5	Clapper Rubber Facing and Clamping Ring	93416104	93416106	93416108	EPDM & Stainless Steel
6	Clamping Ring Screws or Nut (4" Qty 1) (6" Qty 4) (8" Qty 5)	94906124	95606126	95606126	Stainless Steel 18-8
7	Hinge Pin	95006124	95006126	95006128	Brass UNS C 36000
8	Lower Seat "O" Ring	95436124	95436126	95436128	Buna-N
9	Upper Seat "O" Ring	95446124	95446126	95446128	Buna-N
10	Cover Gasket	93706124	93706126	93706128	Neoprene or Buna-N
11	Cover Bolts (Qty 6)	91106124	91106126	91106126	Steel
12	Clapper Spring	96406124	96406124	96406124	Bronze UNS C 51-000
13	Shaft Pipe Plug	98604402	8604402	98604402	Steel
14	Drain Plug (Except Metric Valves)	95206104	95206104	95206104	Steel
-	Retard Chamber	630300522	6303000522	6303000522	Steel

Service Kits

Service kits are available for routine servicing of the valve (reference Figure 9). Service kits for the Model E Alarm Check Valve include the following components:

- Clapper Rubber Facing and Clamping Ring Assembly (item 5)
- Clamping Ring Screws (item 6)
- Cover Gasket (item 10)

4" Model E Service Kit: PN 6501200R18

6" Model E Service Kit: PN 6501200R19

8" Model E Service Kit: PN 6501200R20

The equipment presented in this bulletin is to be installed in accordance with the latest published Standards of the National Fire Protection Association, Factory Mutual Research Corporation, or other similar organizations and also with the provisions of governmental codes or ordinances whenever applicable.

Products manufactured and distributed by Reliable have been protecting life and property for over 90 years, and are installed and serviced by the most highly qualified and reputable sprinkler contractors located throughout the United States, Canada and foreign countries.

Manufactured by

Reliable[®]

Reliable Automatic Sprinkler Co., Inc.

(800) 431-1588

(800) 848-6051

(914) 829-2042

www.reliablesprinkler.com

Sales Offices

Sales Fax

Corporate Offices

Internet Address



Recycled
Paper

Revision lines indicate updated or new data.

EG. Printed in U.S.A. 08/22

P/N 9999970048